



# Fundamentals Of Electro-System

By Er. Prashant Shrestha

## Unit 1 Introduction to Electrostatics

### 1.1 Introduction to Electricity

The area of study that examines the phenomenon of electricity at rest is called **electro statistics**. We know well that matters are made up of tiny particles such as electron, proton, etc. and particles are crucial for electricity.

The force that causes electro to revolve around the nucleus on the orbit or shell is called **Electromagnetic force**.

**Electricity** is created by the flow of electrons. The movement of electrons, especially free electron is what refers to Electricity.

### 1.2 History of Electricity

Electric cells were developed by **Alessandro Volta** in 1800. He used copper and zinc in opposite directions in salt water and observed chemical reactions created current.

**Micheal Faraday** found out that moving magnet through copper wire created a current; which later known as Micheal Faraday law of induction.

**Thomas Alba Edison** made bulb which age light during night using DC current. Later **Nicola Tesla** invented AC current which became the foundation for modern electrical technology.

Turbine driven generators are created in 1890 to produce electricity. The Niagara Falls hydroelectric power plants built by Tesla start producing electricity. Now today, we see more advancement of Electricity generation.

### 1.3 types of Electricity

There are two types of electricity.

- a. Static Electricity
- b. Dynamic Electricity

#### **a. Static Electricity**

Static electricity results from electrons separating from their atoms. The accumulation of an electric charge in one place is known **as static electricity**. The charge remains stationary and does not move. For an example, When we take comb and rub on hairs, The electron of hair gets transferred into comb And now if we take comb near paper pieces then it attracts paper pieces as it has excess number of electron than paper pieces (i.e. positively charged).

The Charge Represented by “**Q**” and its unit is **Coulombs (C)**.

## **b. Dynamic Electricity**

In dynamic electricity, there is a constant flow of electrons from one point to another producing electric current. It travels over wires from a distance. The electricity that is produced by any electrical sources in electrical circuits is said to be as current electricity. Hence the electricity that we use in our home is perfect example of current electricity. All of the electrical devices we use, including phones, electric bulbs, Washing machines, etc. are powered by electric current.

### **Difference between Static and Dynamic electricity by yourself**

#### **1.4 Application and uses of electricity**

- a. Electricity in House
- b. Electricity in Entertainment
- c. Healthcare
- d. Transportation
- e. Industries and factories

#### **1.5 Atom and its component**

The element that is found around is made up atoms. **Atoms** are the smallest unit of an matter or element that inherits the characteristics of matter. **Atoms** are made of three components. They are **proton, neutron, and electron**.

**Proton** is positively charged. **Electrons** are negatively charged, and **Neutrons** are neutral in charge.

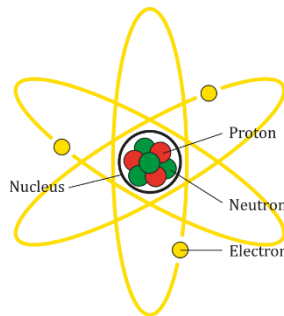

#### **1.6 Atomic number, Atomic Weight, Free Electrons, and Electric charge**

##### **Atomic Number:**

Atomic number can be defined as the total number electrons or protons contained in an atom of element. It is represented by “Z”. Chemical elements can be uniquely identified by its atomic number.

Atomic number = No. of **protons** or No. of **electrons** contained in atom

For example, atomic number of oxygen is 8 as it consists of 8 protons **or** 8 electrons.

### Atomic Weight

The total number of protons and neutrons contained in an atom can be defined as atomic weight. The unit of atomic mass is **a.m.u** (atomic mass unit).

**At.Weight** = total number of neutrons + total number of proton

For example, the atomic weight of oxygen is 16 because it consist of 8 protons and 8 neutrons.

### Free electrons

The electrons which are not bound to the nucleus, and which can freely move in response to external energy sources are known as **free electrons**. The term “electric current” means movement of electron within substance. The materials that **have free electrons** can conduct electric current and the materials which **do not have** free electrons cannot conduct electric current.

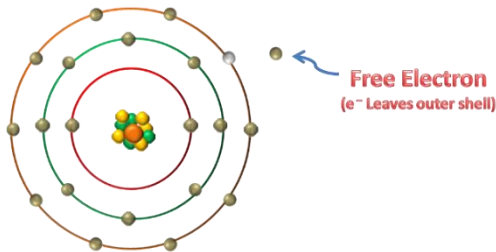

### Electrical Charge

**Electric charge** is a fundamental property of matter that causes it to experience a force when placed in an electric field. An **electric field** is an invisible area around a charged object where it can **push or pull** other charges. positive and negative charge is generated by protons and electrons respectively. Electric charge is produced on atom as electron goes from one atom to another.

Atoms which lose electrons are **positively charged** and atoms which gain electrons are **negatively charged**.

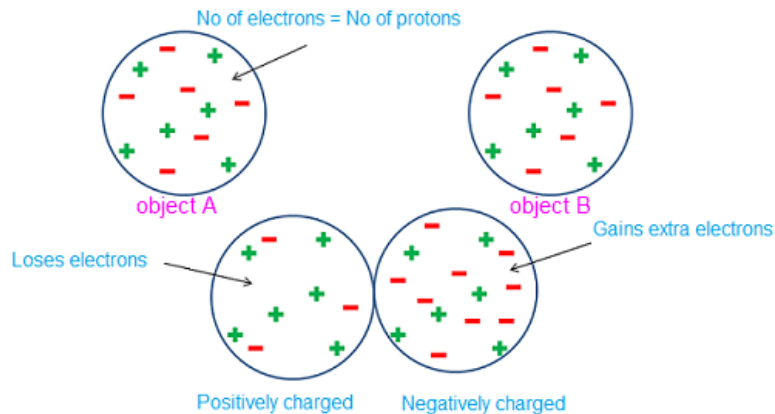

## 1.7 Coulomb's law

Coulomb's law states that “the electrostatic force between any two charged body is directly proportional to the product of the magnitude of these charges and inversely proportional to the square of the distance between them”.

Let us consider two charges “q<sub>1</sub>” and “q<sub>2</sub>” is separated by distance “r” and “F” is the electrostatic force that creates attraction and repulsion between the charges.

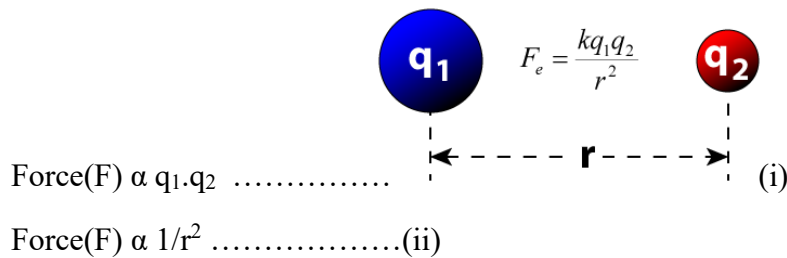

Combining (i) and (ii)

$$F \propto q_1 \cdot q_2 / r^2$$

$$\therefore F = k q_1 \cdot q_2 / r^2$$

Where, k= proportionality constant (Columb's constant) =  $9 \times 10^9 \text{ Nm}^2/\text{C}^2$

## 1.8 Introduction to Electric Field, Potential and Potential Difference

### Electric Field

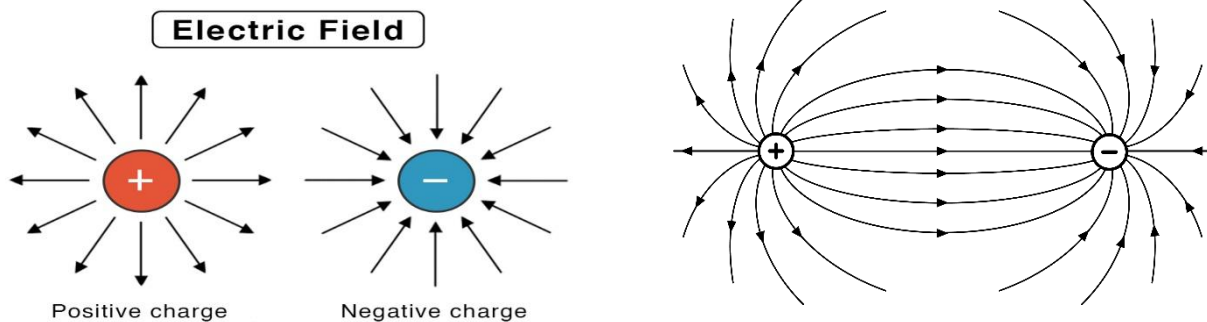

Fig: Electric field

An electric field is a physical field that surrounds electrically charged particles and acts as an attractor or repellent to all other charged particles in the vicinity.

Mathematically,

$$E = F/q$$

Hence, the strength of electric field “E” at any point may be defined as the electric force “F” exerted per unit positive charge “q” at that point.

Electric field are typically shown as lines of force or field lines, which begin on positive charges and end on negative charges.

### **Electric potential**

The amount of energy that requires to move a unit of charge from a reference point to a specific point against an electric field is called electric potential. It is also known as electric potential, potential drop. The potential at reference point is zero unit.

### **Electric potential difference**

**Potential difference** is **the difference in** the amount of energy that charge carriers have between two points in a **circuit**. The charge goes from higher potential to lower potential because there exists a potential difference between two points.

Mathematically,

$$V_A - V_B = \text{work to move charge } q \text{ from B To A} / \text{Charge } q$$

If **1 joule** of work is done **to move 1 coulomb charge** from point B to another point A with a circuit, then the potential difference between the points is said to be **1 volt**.

## **1.9 Electrical Energy, Voltage, and its Unit**

### **Electrical energy**

Electrical energy is the force that is produced from the transfer of electron from one location to another. The basic unit of electrical energy is the **joule** or **watt-second**.

Electrical energy is said to be 1 joule or **watt-second** when 1 ampere (1A) current flows through the circuit for 1 second and is 1 volt potential difference is applied across the circuit.

$$1\text{kWh} = 1000 \times 60 \times 60 \text{ watt-second}$$

### **Voltage**

The force which moves free electron between the atoms is known as **voltage**. Battery or a generator is used to supply voltage. It is represented by symbol “V”. For example, 12V is smaller than 230V.

## Unit 2 Electric Fundamentals

### Voltage

Voltage is an electric force that causes the free electrons to move from one atom to another atom. It is measured in Volts(V). Voltage is measured by an instrument known as Voltmeter. You must connect the voltmeter in parallel with the component to measure a voltage across it in a circuit

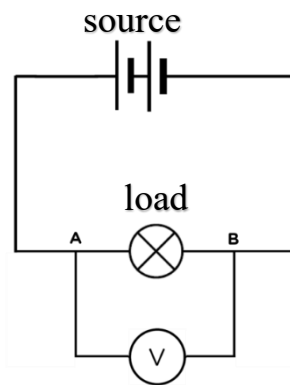

**Fig: voltmeter in parallel with load**

### Current

The rate at which electrons move through a circuit is called **current**. The unit of Current is Ampere, and its symbol is **A**. The instrument that measures the current is called **Ammeter**. The ammeter must be connected in series with the component to measure the current flowing through it.

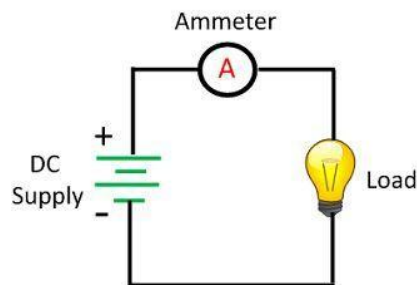

### **Are Voltage and Current related?**

**Ans:** Yes, Voltage and Current are related. In other words, voltage is the cause and current is the effect. Voltage is the force that makes electric charges move and current is the flow of electron caused that force. If there is no voltage, then there will be no current. Let us take an example of simple circuits. Take a battery source and connect to a bulb and it light up because battery source gives voltage and voltage makes charge to flow which gives rise to current. But when the battery is dead, there will be no voltage, so the current does not flow and hence the bulb does not light up. Therefore, voltage and current are related to each other.

## Resistance

Resistance is the ability of a substance to resist the flow of current through it. It is denoted by **R** and its unit is **ohm ( $\Omega$ )**. Mathematically, resistance is given as:

$$\text{Resistance} = \frac{\text{Potential difference}}{\text{current}}$$
$$\text{Or, } R = \frac{V}{I}$$

### **1 ohm resistance**

Resistance is said to be 1 ohm if the potential difference is 1 Volt(V) and the current flowing through conductor is 1 Ampere (A). Mathematically,

$$R = \frac{V}{I}$$
$$\text{Or, } R = \frac{1 \text{ volt}}{1 \text{ amp}}$$

### Movement of Electron in a conductor

Current is produced in a conductor due to the free movement of electric charges in it. In the absence of an electric field(voltage), the electrons in a conductor move randomly. As all the electrons are moving in random directions, there will be **zero** net electric current. Thus, there are no net motions of electrons in a particular direction in the absence of an electric field and hence current is not generated.

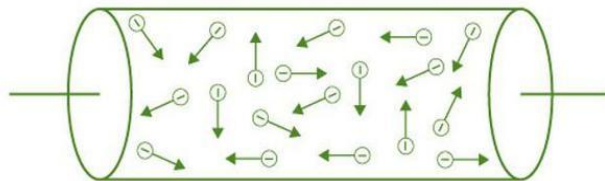

When there is presence of electric field (voltage) in conductor, the electron slowly starts to drift towards the positive terminal of the voltage source and electric current is generated.

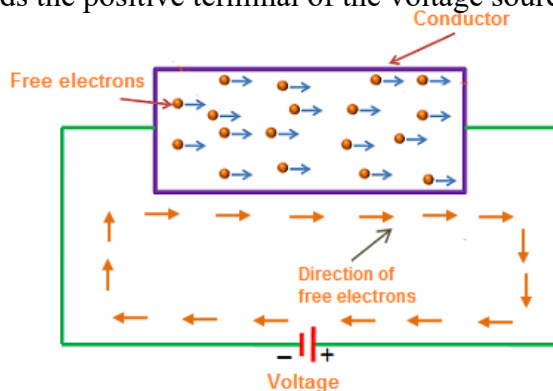

## Sources of Electricity

### 1. Hydro

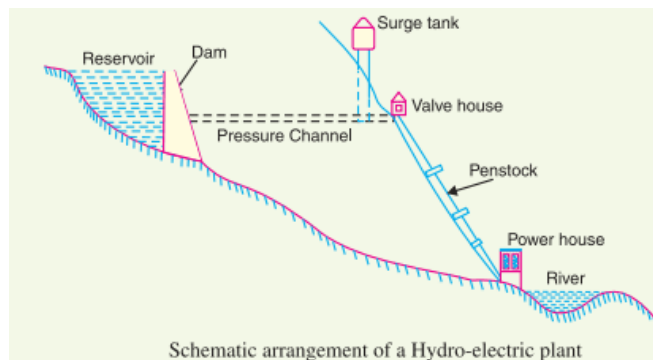

**Hydroelectric power stations** are generally located in hilly areas where dams can be built conveniently, and large water reservoirs can be obtained. Most of the hydroelectric plants use dams to store their water, and the water that goes out is controlled by gates or a valve. Water gains potential energy just before crossing the dam, and as it goes downhill, this potential energy is transformed into kinetic energy. A turbine is rotated by the water and connected to an electric generator that produces electricity.

### 2. Nuclear Fission/Fusion

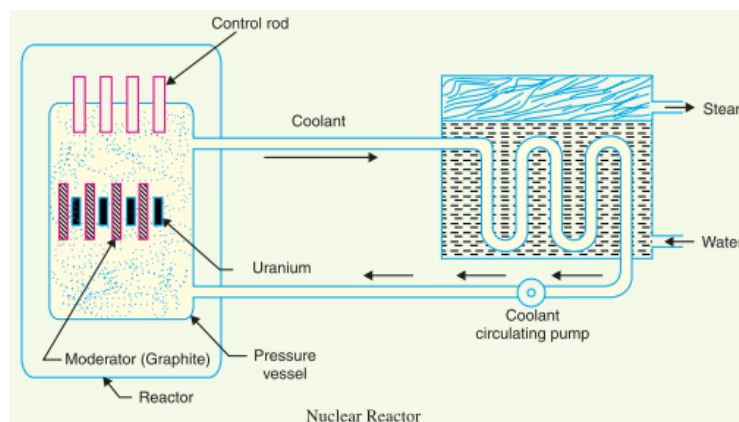

A generating station in which nuclear energy is converted into electrical energy is known as a **nuclear power station**. The idea behind fusion power is to use the heat produced by nuclear fusion reactions to create electricity.

In a **nuclear power station**, heavy elements such as Uranium or Thorium are subjected to nuclear fusion/fission in a special apparatus known as a reactor. The heat energy released by the nuclear reaction is utilized to convert water into steam at high temperature and pressure. The steam runs the steam turbine which converts steam energy into mechanical energy and makes turbine to rotate which converts mechanical energy into electrical energy.

### 3. Wind Energy

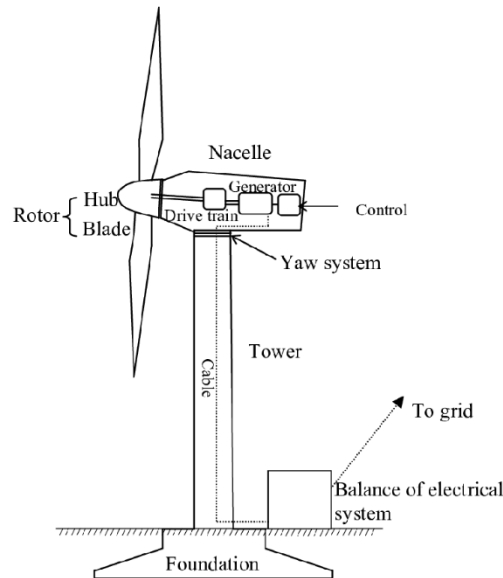

Wind power is the generation of electricity from wind. When wind strikes the turbine blade, it rotates the shaft. The shaft is connected to generator, and which ultimately convert mechanical energy into electricity. Wind speed largely determines the amount of electricity generated by a turbine. Higher wind speeds generate more power because stronger winds allow the blades to rotate faster. Faster rotation translates to more mechanical energy and more electrical energy from the generator.

### 4. Thermal

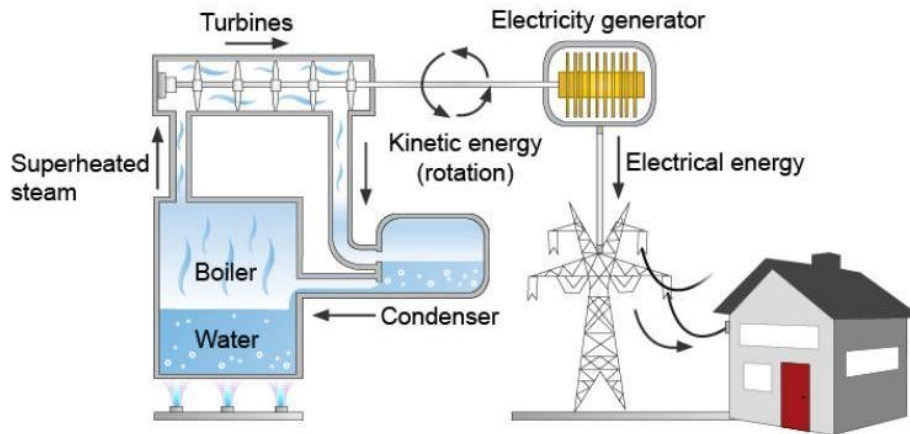

In thermal plants, electricity is produced by using heat. When water is boiled, the superheated steam makes turbine rotate and generates the mechanical energy which is finally converted into electrical energy by the generator.

## 5.Solar

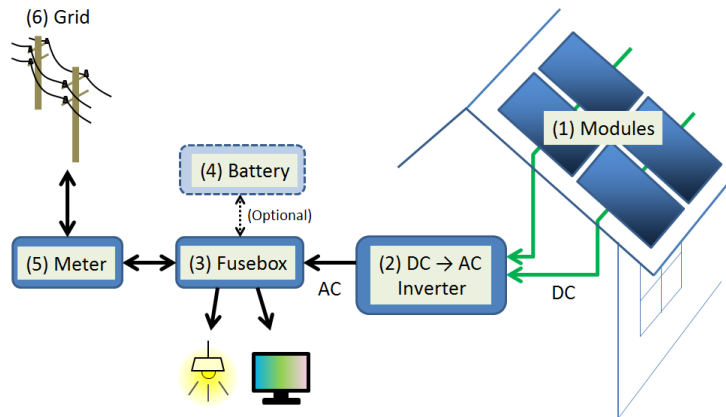

Solar electricity is generated by the sunlight. In the solar system, sunlight is converted into DC (direct current) by photovoltaic cell and the DC current is converted into AC current by inverter. We can use AC current for operating different electric appliances.

### Classification of Object on Basis of Resistance

#### **Conductor**

The material which allows the flow of electricity is called conductor. For example, gold, copper, silver, etc. Conductors have low resistance so current can easily pass through them.

#### **Semi-conductor**

The materials which allow the little amount of electric current to pass through them is known as semi-conductor. The resistance in semi-conductors has a value that falls between conductors and insulators. For example, silicon, germanium etc.

#### **Insulators**

The material which prevents the flow of electric current is called is called insulator. These materials have high resistance so electricity cannot flow through them. For example, wood, paper, plastics, glass, etc.

### Factors Affecting Resistance

The factors that affect the resistance of conductor are as follows:

1. Length of the conductor
2. Cross-sectional area of conductor
3. Temperature of the conductor
4. Nature of the conductor

## 1.Length of the conductor

The resistance of the conductor increases when the length of the conductor increases and vice versa at constant cross-sectional area and constant temperature. So, the resistance of a conductor is directly proportional to length of the conductor. i.e.

$$\text{Resistance}(R) \propto \text{Length } (l) \dots\dots\dots (i)$$

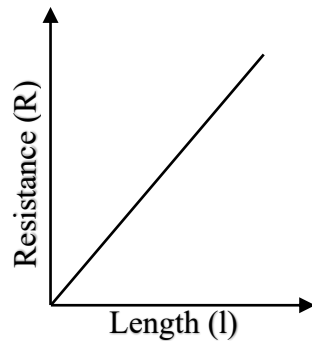

Fig: Relationship between resistance and length of conductor

From the above graph, we see that when the length of conductor is increased, resistance is also increased with respect to length of conductor.

## 2.Cross-sectional area of conductor

The resistance of conductor is inversely proportional to the cross-sectional area of conductor. i.e.

$$\text{Resistance}(R) \propto \frac{1}{A} \dots\dots\dots (ii)$$

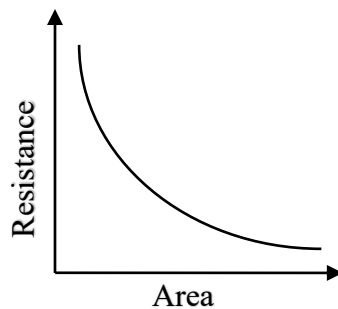

Fig: Relationship between Resistance and Area of Conductor

From the above graph we can conclude that when the cross-sectional area is increased, the resistance of conductor decreases.

### 3. Temperature of the Conductor

The resistance of conductors increases with the increase of temperature and vice versa keeping the cross-sectional area and length of conductor constant. Resistance of conductors at given temperature is given by:

$$R_{\theta} = R_0(1 + \alpha\theta)$$

Where,

$R_{\theta}$  = resistance at given temperature

$R_0$  = resistance at  $0^{\circ}$  C

$\alpha$  = temperature coefficient of resistance ( $^{\circ}\text{C}^{-1}$ )

$\theta$  = given temperature

### 4. Nature of Conducting Materials

The resistance of conductors is dependent on the material which it is made up of. The resistance of nichrome is 60 times greater than the resistance of copper so, we use copper for wiring purposes other than nichrome.

Combining equations (i) and (ii)

$$R \propto \frac{1}{A}$$

$$\text{Or, } R = \rho \frac{1}{A}$$

Where,

$\rho$  is a proportionality constant known as resistivity of conductor and also known as specific resistance.

## Unit 3 Electric Circuit

### Electric Circuit

The path in which current flows from source to load (e.g. Lamp, computer, speaker, etc.) through a conductor is called electric circuit.

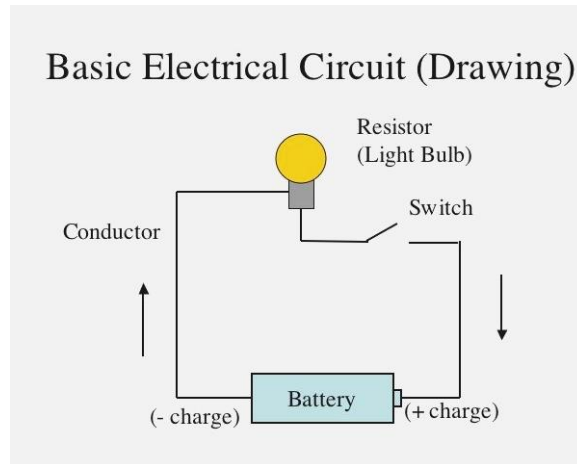

### Types of Electrical Circuits

There are different types of circuit. Some of them are explained below

1. Open circuit
2. Closed circuit
3. Short circuit
4. Series circuit
5. Parallel circuit
6. Mix circuit

#### 1. Open circuit



Open Circuit Diagram

The circuit in which the switch is open, and current does not flow through the circuit is called an open circuit. Since open circuits offer infinite resistance, current in the circuit becomes zero and hence there is no voltage drop across the load

## 2. Closed circuit

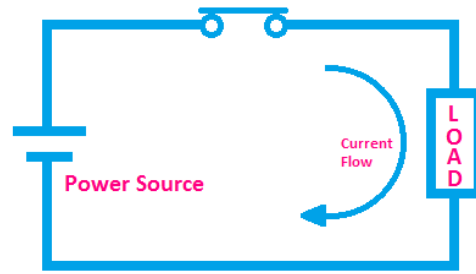

Closed Circuit Diagram

A circuit in which the switch is closed and current flows through the circuit is called an open circuit. In closed circuit, there is voltage drop across the load as current flows through the circuit.

## 3. Short circuit

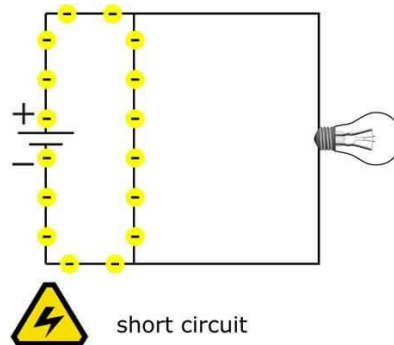

The circuit in which the current flows through the circuit without any resistor is called short circuit. Short circuit occurs when the positive (+) and negative (-) terminals of a voltage source in circuit come into contact with one another for any reason without any load between two terminals.

## 4. Series Circuit

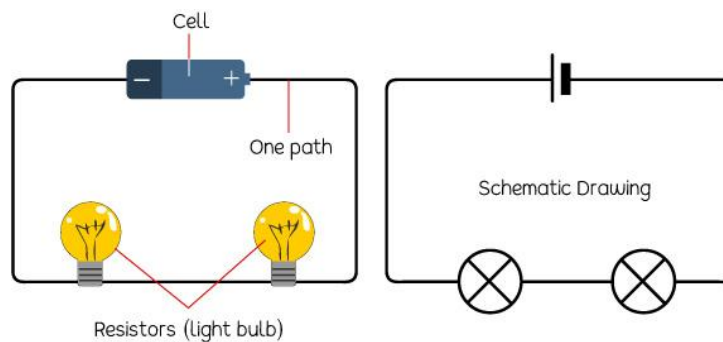

The circuit in which electrical components are connected one after another in single path is called series circuit. Same current flows through all components and voltage may differ across each component in series circuit.

## 5. Parallel circuit

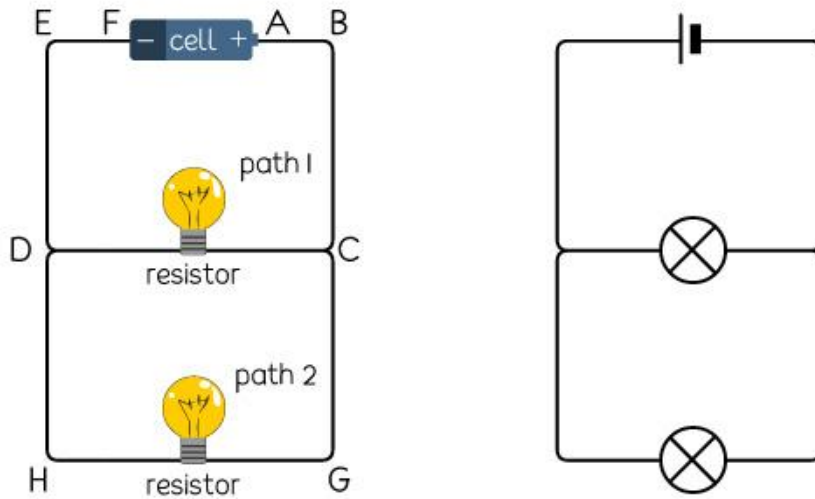

A parallel circuit is a type of electrical circuit where the components (such as resistors, bulbs, or appliances) are connected across common points or junctions, forming branches so that the current divides and flows through multiple paths. Same voltage is applied across each component.

## 6. Mix circuit

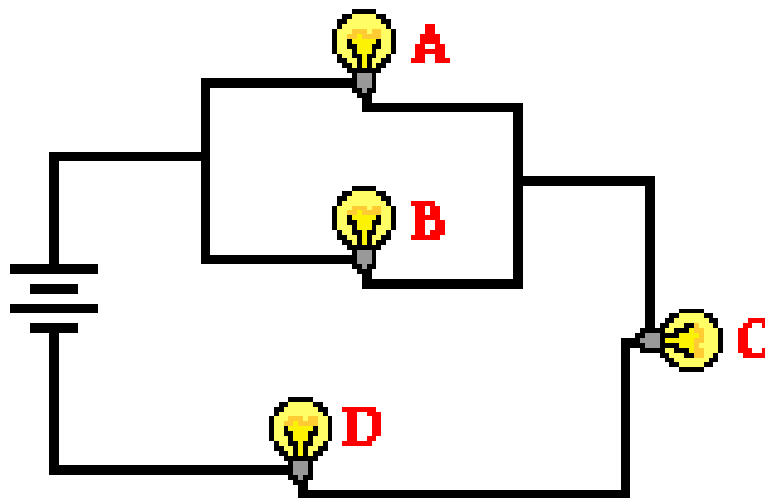

The circuit in which there is a combination of series and parallel combination is called mix circuit. It is also known as series-parallel circuit.

## Resistance in Series Circuit

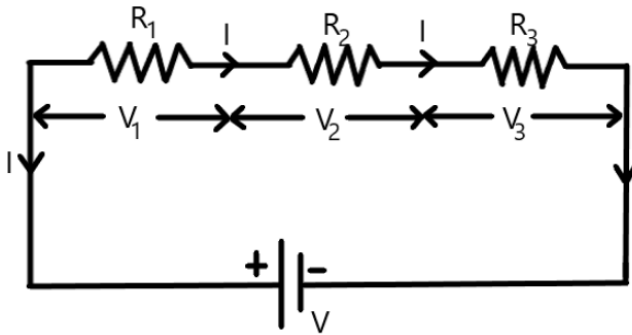

Let us consider that four registers **R<sub>1</sub>**, **R<sub>2</sub>**, and **R<sub>3</sub>**, and **R<sub>4</sub>** are connected in a series combination. In Series Circuit, Same current flows through each resistor but voltage across each resistor is different and it is additive in nature, so

$$V=V_1+V_2+V_3 \dots\dots\dots(i)$$

Each voltage drop can also be expressed using Ohm's Law:

$$V_1=IR_1, V_2=IR_2, V_3=IR_3$$

From equation (i)

$$V=V_1+V_2+V_3$$

$$\text{Or, } V=IR_1+IR_2+IR_3$$

$$\text{Or, } IR_{eq} = I(R_1+R_2+R_3)$$

$$\text{Or, } R_{eq}=R_1+R_2+R_3$$

$$\therefore R_{eq}=R_1+R_2+R_3$$

For n number of register, the general formula for equivalent resistance is given by

$$R_{eq}=R_1+R_2+R_3+\dots\dots\dots +R_n$$

## Resistance in Paralle Circuit

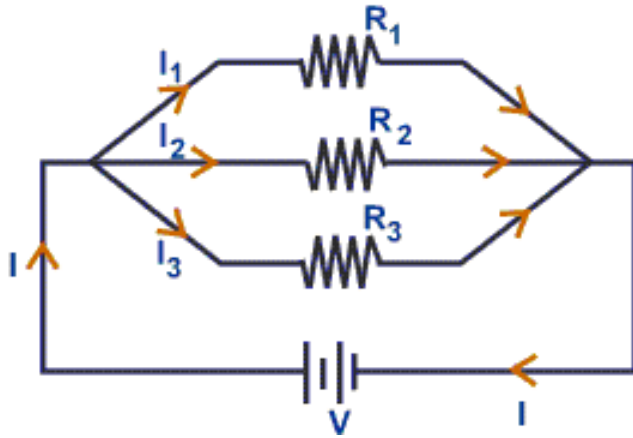

Let us consider three resistors connected in parallel combination. In parallel connection voltage across each resistor is same but different current flows in each resistor and it is additive so

$$I = I_1 + I_2 + I_3 \quad \dots\dots\dots (i)$$

Current in each resistor is given by Ohm's Law

$$I_1 = \frac{V}{R_1}, \quad I_2 = \frac{V}{R_2}, \quad I_3 = \frac{V}{R_3}$$

From equation (i)

$$I = I_1 + I_2 + I_3$$

$$\text{Or, } I = \frac{V}{R_1} + \frac{V}{R_2} + \frac{V}{R_3}$$

$$\text{Or, } \frac{V}{R_{\text{eq}}} = V \left( \frac{1}{R_1} + \frac{1}{R_2} + \frac{1}{R_3} \right)$$

$$\text{Or, } \frac{1}{R_{\text{eq}}} = \frac{1}{R_1} + \frac{1}{R_2} + \frac{1}{R_3}$$

For "n" number of resistor the general formula is given by

$$\boxed{\frac{1}{R_{\text{eq}}} = \frac{1}{R_1} + \frac{1}{R_2} + \frac{1}{R_3} + \dots + \frac{1}{R_n}}$$

**Note:**

**Follow your book for following topics**

voltage divider rule, current divider rule, ohm's law, and it's application, Kirchoff's current law, Kirchoff's voltage law characteristics of Series and parallel circuit.

## Unit 4 Electrical Power and Theory

### 4.1 Introduction to Electric Power

Electric power is the rate of energy transmission into or out of circuit that uses electricity. Energy can be supplied by a battery or release as heat by a register or other component of a circuit.

The potential difference “V” across the conductor causes the current “I” to flow through it. This implies that there is an electrical work done “W” then to moving the charge “q” in the circuit, this is called an electrical work done. Its unit is joule. Therefore

$$w = V \times q$$

$$\text{Or, } w = V \times (I \times t)$$

$$\therefore w = V \times (I \times t) \dots\dots\dots(i) \quad (I = q/t)$$

Where t is time for which current flows

Power is the rate of doing work, so

**Power (P) = Work done / time**

$$\text{Or, } P = w/t \dots\dots\dots(ii)$$

$$\text{Or, } P = V \times (I \times t) / t \quad \text{from equation (i)}$$

$$\text{Or, } P = V \times I$$

$$\therefore P = V \times I$$

If we want to express Power in terms of expression containing resistance,

$$P = V \times I$$

$$\text{Or, } P = IR \times I \quad (\text{since, Ohms's law } V = IR)$$

$$\therefore P = I^2 R$$

### 4.2 Units of electrical power

The rate at which electrical energy is spent or changed into another type of energy, such as heat, light, or mechanical power is called electric power.

It is measured in **watts (W)**.

### 4.3 Electrical Energy

The energy produced due to the flow of electrons is known as electrical energy. In other words electrical energy means the amount of work done by an equipment during a time period of “t”.

Mathematically,

Energy (E) = Power (P) x Time (t)

$$\therefore E = P \times t \dots\dots\dots (i)$$

Now substituting the using the formula of power

$$E = IV \times t$$

$$\therefore E = I \times V \times t \dots\dots\dots (ii)$$

**The heating effect of current**

$$E = I \times V \times t$$

Or,  $E = I \times I \times R \times t \dots\dots\dots$  (from ohm's law  $V=IR$ )

$$\therefore E = I^2Rt$$

Above electrical energy will be converted into heat energy and the electrical energy is said to be consumed by the electric circuit. This is known as the heating effect of current and the heat developed in a circuit is given by the relation,

$$H = I^2Rt$$

**This relation is known as Joule's law of heating.** According to it, the heat produced on the conductor is directly proportional to:

- i. Square of the magnitude of current flowing through the conductor.
- ii. Resistance of a conductor
- iii. Time for which the current is passed over to the conductor.

**4.4 Numerical**

**1. The resistance of the element of the heater is  $900\Omega$  and a current of  $1.5A$  is flowing through the circuit. Find the power dissipated in the circuit.**

Soln. Here,

$$\text{Resistance (R)} = 900 \Omega$$

$$\text{Current (I)} = 1.5 \text{ A}$$

Now.

$$\text{Power (P)} = I^2R$$

$$= (1.5)^2 \times 900 = 2025 \text{ watt}$$

**2. An electric heater operates on 220 V and draws a current of 6 A. Calculate the power consumption.**

Soln. Here,

$$\text{Voltage (V)} = 220\text{V}$$

$$\text{Current (I)} = 6 \text{ A}$$

Now.

$$\text{Power (P)} = IV$$

$$= 6 \times 220$$

$$= 1320 \text{ watt}$$

**3. An electric heater of 220V is used on 8A. Find the power consumed by it. Also, find the cost of using the heater for one hour if the rate of electricity is Rs. 6 per unit.**

Soln. Here,

$$\text{Voltage(V)} = 220\text{V}$$

$$\text{Current (I)} = 8\text{A}$$

$$\text{Time used} = 1 \text{ hr}$$

Now.

$$\text{Power (P)} = IV$$

$$= 8 \times 220$$

$$= 1760 \text{ watt}$$

$$= 1.76 \text{ kw}$$

And,

$$\text{Electrical energy consumed} = 1.76 \times 1$$

$$= 1.76 \text{ kw-hr}$$

$$\therefore \text{Cost} = \text{Rs. } 1.76 \times 6 = \text{Rs. } 10.56$$

**4. The current passing through a filament lamp is 2A. If it is connected to a 12 V power supply. Calculate the resistance of the filament and power consumed by the lamp.**

Soln. Here,

Voltage supply (V) = 12 V

Current (I) = 2 A

Now. From Ohm law, we have

$$V=IR$$

$$\text{Or, } R=V/I$$

$$\text{Or, } R=12/2$$

$$\therefore R=6\ \Omega$$

And,

$$\text{Power (P) = IV}$$

$$= 2 \times 12$$

$$= 24 \text{ watt.}$$

## Unit 5 Cell and Capacitor

### 5.1 Introduction to Cell and Battery

#### Cell

The electrochemical device which can convert stored chemical energy into electrical energy is called a cell. It is the basic unit of the battery.

The rate of chemical reaction in the cell depends upon the surface area of the electrodes, temperature, and the load connected across the cell.

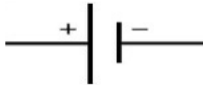
The symbol of a cell is. 

#### Battery

The combination of two or more cells in a series or parallel combination is known as a battery. The number of cells in a battery is related to the desired voltage and required current. The symbol of a battery is

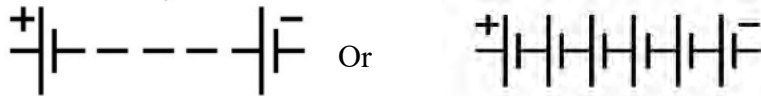

### 5.2 Types of cell/battery

Batteries can be broadly divided into two major types

- a. Primary cell/battery
- b. Secondary cell/battery

#### **a. primary cell/battery**

The cell in which chemical substances produce electromagnetic force (emf) by chemical reaction is known as the primary cell. The chemical action in this cell is not reversible. Since this cell cannot be revived, this cell is called a non-rechargeable cell. After the cell is used, the substances in it become useless. The commonly used primary cells are Voltaic cell, Daniel Cell, Lechlance cell and so on

#### **b. Secondary cell/battery**

The cell in which chemical action is reversible; the electrolytes and electrodes can be restored to the previous state once it is used up is the secondary cell. This cell is first charged from the external source and then it gives electric current storing electric energy in the form of chemicals. It is also called a storage cell because this cell is rechargeable. For example: Lead Acid Cells, nickel, cadmium cells, etc.

### 5.3 Series and parallel connection of cell

#### **Series connection of cell**

A set of batteries are said to be connected in series when the positive terminal of one cell is connected to the negative terminal of the succeeding cell. In a series connection, the individual voltages of the cells add up, but the current capacity of a battery remains constant since the same current passes through all of the cells. Circuit having series connection of cell shows the following characteristics

- The EMF of the battery is the sum of the individual Emfs.
- The current in each cell is the same and is identical with the current in the entire arrangement.
- The total internal resistance of the battery is the sum of individual internal resistance.

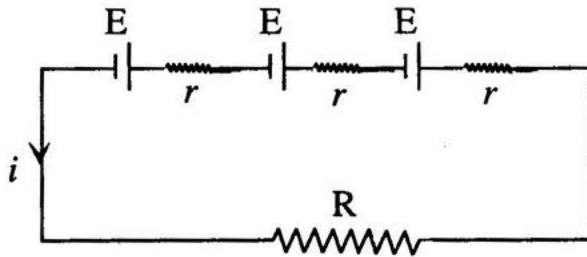

When cells are connected in series, total emf is given by the sum of their emf and the sum of their internal resistances.

$$\text{Total EMF (E)} = E_1 + E_2 + E_3 + \dots + E_n$$

$$\text{Total internal resistance (r)} = r_1 + r_2 + r_3 + \dots + r_n$$

If similar cells of emf 'E' and internal resistance 'r' are connected in series, then

$$\text{Total emf (E}_{eq}) = nE$$

$$\text{Total internal resistance (r}_{eq}) = nr$$

#### **Parallel connection of cell**

Cells are said to be in parallel when all the positive terminals are connected at one point and all the negative terminals are connected at another point. Circuit having parallel connection of the cell shows the following characteristics.

- The EMF of the battery is the same as that of a single.
- The current in the external circuit is divided equally among the cells.

- The reciprocal of the total internal resistance is the sum of reciprocals of the individual internal resistance.

The overall flowing through the circuit is the algebraic sum of all individual currents flowing through parallel branches.

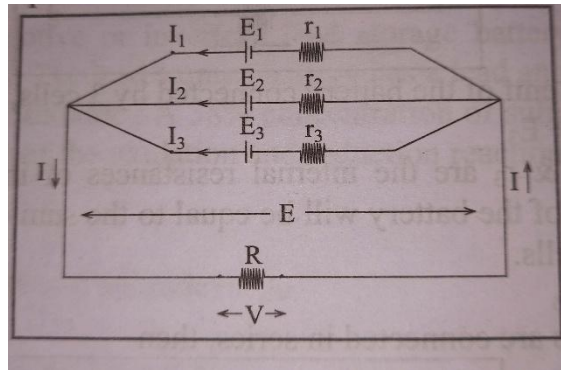

From above circuit,

$$E = V = E_1 = E_2 = E_3$$

The overall current flowing through the circuit is the algebraic sum of all individual currents flowing through parallel branch

$$I = I_1 + I_2 + I_3$$

Internal resistance is reciprocal of internal resistance of individual cells

$$\text{i.e. } r = (1/r_1 + 1/r_2 + 1/r_3)^{-1}$$

$$= ((r_2 r_3 + r_1 r_3 + r_1 r_2) / r_1 r_2 r_3)^{-1}$$

$$= r_1 r_2 r_3 / r_1 r_2 + r_2 r_3 + r_1 r_3$$

If 'n' number of cells are connected in parallel, then

$$r = (1/r_1 + 1/r_2 + \dots + 1/r_n)$$

## 5.4 Capacitor, Capacitance and its Units

Capacitor is an electrical device capable of storing charge within its electric field. It consists of two conducting surfaces separated by a layer of insulating substance known as dielectric. The SI of capacitor unit is Farad (F).

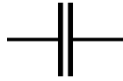

Fig. symbol of capacitor

Capacitance can also be defined as the charge required to produce a unit of potential difference between the plates. If the 'Q' charge is stored in the plates to produce a potential difference of 'V' volts, then

$$\text{Capacitance (C)} = Q/V$$

### **1 F Capacitance**

Capacitance can be defined as the capacitance of the capacitor when 1 coulomb of charge is stored producing a potential difference of 1 V between the plates.

### **Calculation of capacitance of a parallel plate capacitor**

Consider a parallel plate capacitor, fully charged as shown in figure.

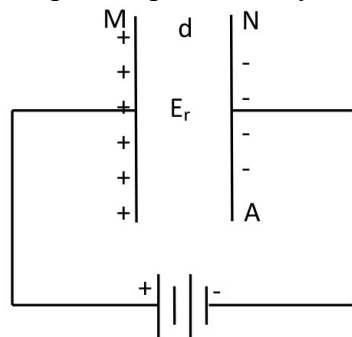

The area of estate M and N is say AM square and bits are connected by distance D. The relative permittivity of the dielectric Used in between plates be  $\epsilon_r$

Let C be the capacitance of parallel plate capacitor and capacitance is directly proportional to the cross-sectional area of the plate and inversely proportional to the distance between the plates. So,

Mathematically,

$$C \propto A \dots\dots\dots(i)$$

$$C \propto 1/d \dots\dots\dots(ii)$$

From equation (i) and (ii)

$$C \propto A/d$$

$$\text{Or } C = \epsilon A/d$$

$$\text{Where } \epsilon = \epsilon_0 \epsilon_r$$

Then,

$$C = \epsilon_0 \epsilon_r A/d$$

Where,

$\epsilon_0$  = Absolute permittivity ( $8.85 \times 10^{-12}$ )

$\epsilon_r$  = Relative permittivity

**Note:**

### **Values of dielectric constants for some medium**

- i) Vacuum – 1 F/mv
- ii) Air – 1.004 F/m
- iii) Mylar – 3 F/m
- iv) Paper – 5 F/m
- v) Mica – 6 F/m
- vi) Glass – (4-18) F/m
- vii) Barium Titanate ( $\text{BaTiO}_3$ ) – (1500-2000) F/m
- viii) Other formulated ceramics – (8000-20000) F/m

### **5.5 Factors Affecting Capacitance**

- a. Capacitance is directly proportional to the surface area (A) of conducting plates. Larger plate surfaces enable more charge to be stored.
- b. Capacitance is inversely proportional to the distance (d) between plates. Because the electric field is stronger at shorter distances, capacitance increases.
- c. The dielectric substance between the plates influences capacitance via its dielectric constant. A higher dielectric constant increases capacitance.
- d. The permittivity of a dielectric material indicates how easily electric field lines can travel through it. Higher permittivity leads to increased capacitance.
- e. Capacitance can change with temperature.

## 5.6 Characteristics of capacitance

- a. Capacitance refers to the ability to store and release electrical energy in the form of an electric field between two conductors.
- b. Capacitance is proportional to the electric charge stored and the potential difference applied between the conductors.
- c. The capacitance value is determined by the geometry of the conductors (area and separation distance) as well as the dielectric material used between them.
- d. Different dielectric materials influence capacitance because their dielectric constant increases the ability to store charge.
- e. Capacitance determines how much energy is stored in the electric field.

## 5.7 Series and Parallel Plate Capacitor

The capacitors can be connected to a circuit in different ways.

1. Series combination
2. Parallel Combination

### **1. Series combination of capacitors**

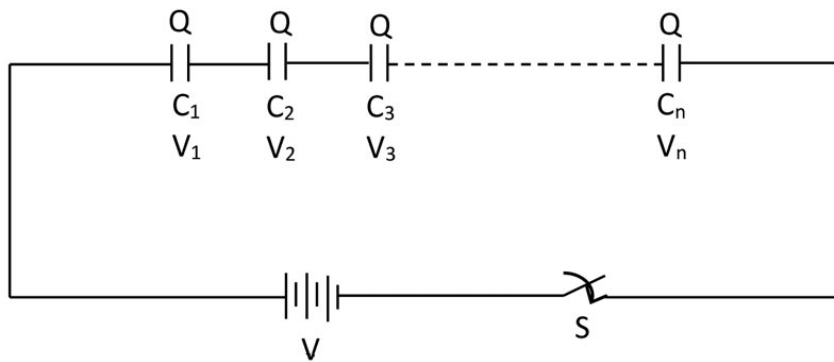

Let  $C_1, C_2, C_3, \dots$  and  $C_n$  be capacitances of the capacitors connected in series to a voltage source of ' $V$ ' volts.  $C_{eq}$  is the equivalent capacitance of the capacitors connected to the above series circuit. Since the same charge flows through all of them and potential difference will be different and additive.

$$\text{i.e. } V = V_1 + V_2 + V_3 + \dots + V_n$$

$$\text{or, } \frac{Q}{C_{eq}} = \frac{Q}{C_1} + \frac{Q}{C_2} + \frac{Q}{C_3} + \dots + \frac{Q}{C_n}$$

$$\text{or, } \frac{Q}{C_{eq}} = \left( \frac{1}{C_1} + \frac{1}{C_2} + \frac{1}{C_3} + \dots + \frac{1}{C_n} \right) Q$$

$$\text{or, } \frac{1}{C_{eq}} = \frac{1}{C_1} + \frac{1}{C_2} + \frac{1}{C_3} + \dots + \frac{1}{C_n}$$

## 2. Parallel combination of capacitor

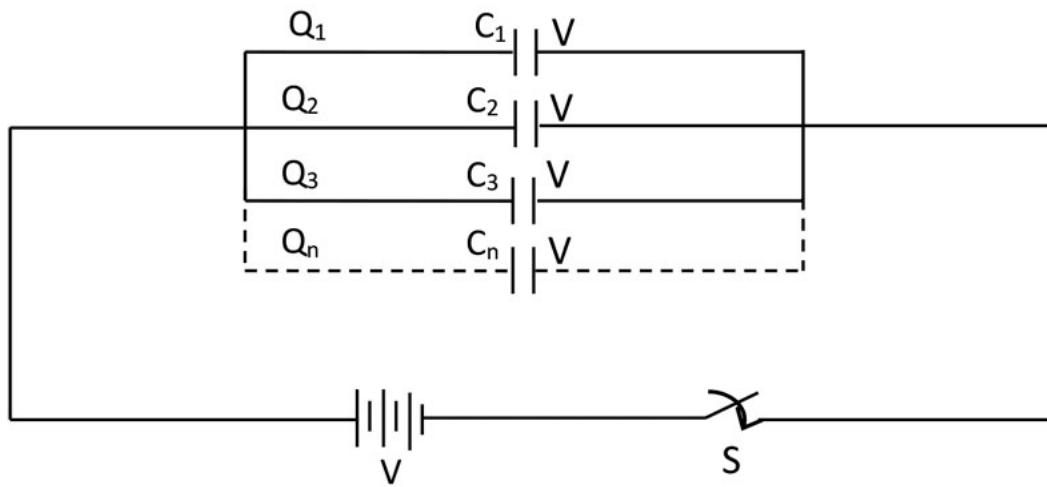

Let  $C_1, C_2, C_3, \dots$  and  $C_n$  be capacitances of the capacitors connected in parallel across a voltage source of 'V' volts. And  $C_{eq}$  is the equivalent capacitance of the capacitors connected to the above parallel circuit. Since in parallel combination, the potential difference across each capacitor will be the same and the charge stored in each of the capacitors will be different and additive.

$$\text{i.e. } Q = Q_1 + Q_2 + Q_3 + \dots + Q_n$$

$$\text{or, } C_{eq} V = C_1 V + C_2 V + C_3 V + \dots + C_n V$$

$$\text{or, } C_{eq} V = (C_1 + C_2 + C_3 + \dots + C_n) V$$

$$\text{or } C_{eq} = C_1 + C_2 + C_3 + \dots + C_n$$

## **UNIT 6 Magnetism and Electromagnetism**

### **6.1 Introduction to Magnet and Magnetism**

#### **Magnet:**

A magnet is substance or object that has property to attract magnetic materials. A magnet has following properties:

- It has two poles north and south poles. It is assumed that magnetic particles have north and south poles.
- Unlike poles attracts and like pole repel each other
- It stays in south and north direction while hanged with strength
- Magnetic core is induced in any attached magnetic materials.
- The poles never separate from each other in a particle of magnet

#### **Magnetism**

An attractive and repulsive phenomena caused by a moving electric charge is known as magnetism. Both an electric and a magnet field are present in the area that is affected by a moving charge. The electromagnetic force is moving electric charge produce by magnetism.

### **6.2 Types of magnet**

#### **1. Temporary magnet**

Temporary magnets can be magnetized in the presence of a magnetic field. When the magnetic field is removed, these materials lose their magnetic property. Some iron and iron alloys act as temporary magnets, as well as paper clips and nails.

#### **2. Permanent magnet**

Permanent magnets are those magnets that are commonly used. They do not lose their magnetic property once they are magnetized so they are known as permanent magnet.

#### **3. Electro magnet**

Electromagnets consist of a coil of wire wrapped around a metal core made from iron. When this material is exposed to an electric current, a magnetic field is generated, making the material behave like a magnet. The strength of the magnetic field can be controlled by controlling the electric current.

### **6.3 Magnetic and non-magnetic materials**

#### **Magnetic materials**

The materials that can get attracted to the magnets are called Magnetic materials. Examples:- Nickel, Cobalt, Iron and Steel. Magnetic materials can be magnetized.

### 1. Dia-magnetic substance:

The substance that are repelled by the magnet are known as dia-magnetic substance. For eg, gold, silver, etc.

### 2. para-magnetic substance:

The substance that are weakly attracted by the magnet are known as para-magnetic substance. For eg: Aluminum, platinum, etc.

### 3. Ferro-magnetic substance:

The substance that are strongly attracted by the magnet are known as ferro-magnetic substance. For eg: iron, steel etc.

### Non magnetic materials

The materials that do not get attracted to the magnets are called Non-magnetic materials. Examples:- Wood, Plastic, Rubber, Copper, etc. Magnetic materials cannot be magnetized

## 6.4 Introduction to magnetic terminologies

### Magnetic field

The area surrounding a magnetic substance or moving electric charge where the force of magnetism acts is known as the magnetic field.

### Magnetic Lines of force

Magnetic lines of force (or magnetic field lines) are imaginary lines used to visualize the direction and strength of a magnetic field around a source, such as a magnet or current-carrying wire.

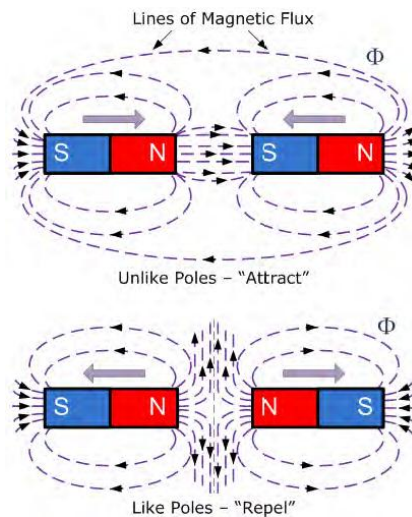

Properties of magnetic field lines

1. Magnetic field lines always originate from the north pole and end at south pole.
2. Lines of a magnetic field never cross one another.
3. Magnetic force is at the poles of a magnet.
4. Magnetic field lines form closed loop only.
5. The magnetic lines of force comes closer near to the poles and widely separated at other place.

### **Magnetic flux**

The total no of force produced in any magnetic field is known as magnetic flux. It is denoted by  $\Phi$ , and its SI unit is weber (W b). The more the magnetic lines of force, the more the magnetic flux, hence the more stronger magnetic field.

### **Magnetic flux density**

The total no of magnetic lines of force through units surface area (A) normally (being perpendicular) is known as a magnetic flux density. It is denoted by 'B' and its SI unit is Tesla.

Formula:

Magnetic flux density (B) = Magnetic flux/Area

$$B = \Phi/A$$

$$= \text{wb /m}^2(\text{Tesla})$$

### **6.5 Magnetic effect of current and its Application**

An electric current flowing in wire produces a magnetic field around it. E.g. when a compass is brought near a current carrying conductor the needle of compass gets deflected because of flow of electricity.

#### **Applications of electromagnets (follow your book page no. 116)**

**a. Electric motors:** The interaction between a rotating electromagnet and a permanent magnet creates torque, which is the turning force that powers electric motors in appliances, fans, and power tools.

**b. Generators:** In generators, rotating magnet induces a current in a coil of wire, converting mechanical energy into electrical energy.

## Rules for finding the direction of Magnetic Needle

### 1. Swim rule

Swimming rule states that if a swimmer swims in the direction of current facing a magnetic needle, then the north pole of the magnetic needle deflects towards his left hand, and the south pole towards his right hand.

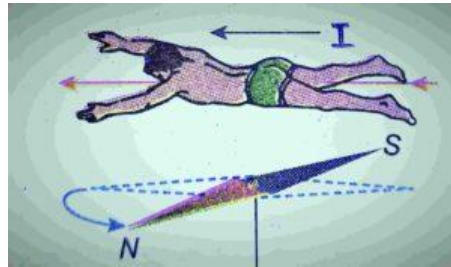
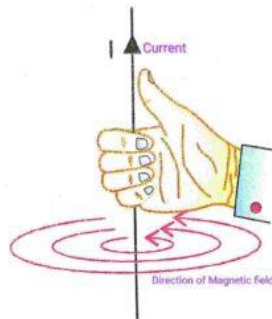

Fig: diagram for Ampere's swimming rule

### 2. Right-hand thumb rule or right-hand grip rule

Ampere's right-hand rule states that if a current-carrying conductor is held in a grip in the right hand, such that the thumb indicates the direction of current through the conductor, then the curl of the remaining four fingers indicates the direction of the magnetic lines of force due to the current



Fleming's right-hand Thumb rule

### 3. Right hand screw rule

Right-hand screw Rule sometime is also called the Maxwell's Corkscrew Rule. Imagine a right handed screw being turn so that it bores its way in the direction of the current in the wire. The direction of rotation gives the direction of the magnetic field.

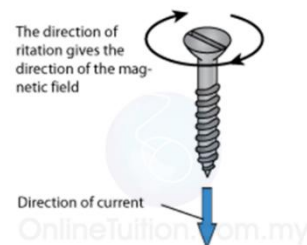

Maxwell's Screw Rule

#### 4. Right-hand palm rule

If we take the right hand with the thumb pointing in the direction of current and the palm facing the conductor, then the fingers show the direction of the magnetic field lines

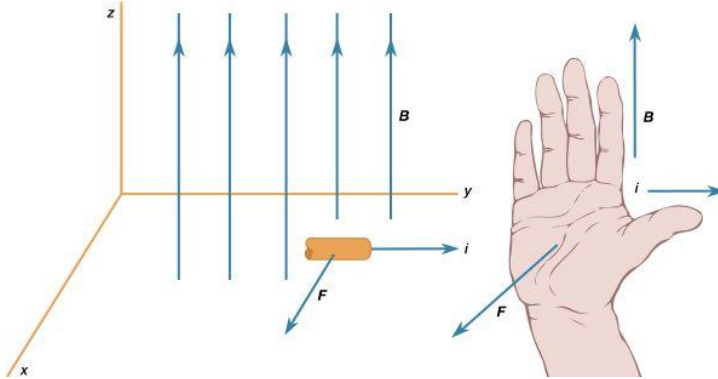

### 6.6 Principle of electromagnetism

#### **Electromagnetism:**

Electromagnetism is a fundamental branch of physics that deals with the study of electric and magnetic fields and their interactions with matter. Electric charges generate electric fields. The force between two charges is described by Coulomb's Law. An electric field ( $E$ ) exerts a force on other charges within the field. A changing electric field generates a magnetic field and vice versa.

#### **Electromagnet:**

An electromagnet is a type of magnet in which the magnetic field is produced by an electric current. When an electric current flows through a coil of wire, it generates a magnetic field. The strength of this field is proportional to the current and the number of turns in the coil.

#### **Electromagnetic Induction**

Electromagnetic Induction is a current produced because of voltage production (electromotive force) due to a changing magnetic field. This either happens when a conductor is placed in a moving magnetic field (when using an AC power source) or when a conductor is constantly moving in a stationary magnetic field.

## Fraday's experiment

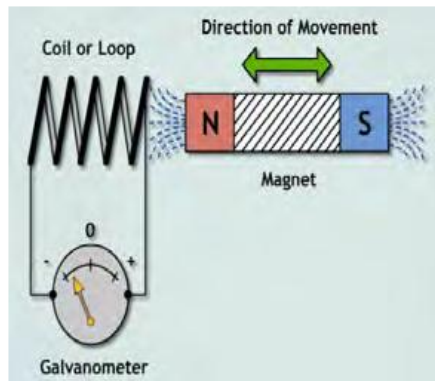

Michael Faraday's experiments in the early 19th century demonstrated the fundamental principle of electromagnetic induction, which is the generation of an electric current by changing magnetic fields. One of his classic experiments involved using a galvanometer, a coil of wire, and a magnet. The coil is connected to the galvanometer. The magnet is initially at rest, far from the coil, so no current is observed in the galvanometer.

When the magnet is moved towards the coil, the magnetic field through the coil changes. This changing magnetic field induces an electromotive force (EMF) in the coil and shows the deflection in the galvanometer which indicates the presence of induced EMF.

The direction of the induced current depends on the direction of the magnet's motion. The speed of the magnet's movement affects the magnitude of the induced current. Faster movement results in a greater change in magnetic field and a stronger induced current.

### 6.7 Faraday's law of Electromagnetic induction

Faraday's law of electromagnetic induction, also known as Faraday's law, is the basic law of electromagnetism which helps us to predict how a magnetic field would interact with an electric circuit to produce an electromotive force (emf).

#### It states that

- a) When the magnetic flux linked with the closed circuit changes, an electromotive force (emf) is induced in the circuit.
- b) The magnitude of induced emf is directly proportional to the rate of change of magnetic flux.
- c) The induced emf lasts in the circuit as long as the change in the magnetic flux continues.

**Lenz's Law:**

This rule is based on the principles derived by German Physicist Heinrich Lenz According to Lenz's law, "An induced emf generated by electromagnetic induction is such that it sets up a current which always opposes the cause that is responsible for generating the emf". In other words, the induced emf always opposes the cause that produces it, which is denoted mathematically by a negative sign.

$$E = -N * (d/dt) \text{ volt.}$$

Where,

E – Induced emf

d – Change in magnetic flux

N – No. of turns of coil

## Unit 7 Fundamentals of current and phase current

### 7.1 Introduction to AC and DC

#### DC Current

Direct current (DC) refers to the unidirectional passage of electric charge. Batteries, thermocouples, power supplies, solar cells, and other sources all generate direct current. A rectifier circuit can be used to convert an alternating current supply into direct current. Direct current can also be transformed into alternating current using an inverter or a motor-generator set.

#### **Points to Remember**

- The magnitude of DC remains constant.
- The direction of DC is fixed.
- It is produced by cells.
- The frequency of DC is 0.
- Conversion of DC into AC is not simple.
- Transmission of DC signals over higher distances is difficult.
- With the same rating DC is more dangerous than AC.

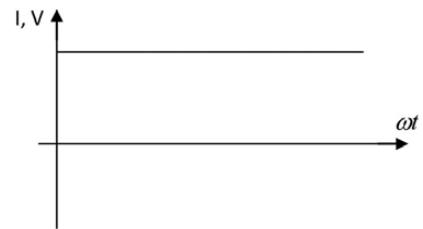

#### AC Current

Alternating current (AC) is an [electric current](#) that periodically reverses direction and changes its magnitude continuously with time. Generators produce alternating current (AC). Alternating currents are more widely used because they are easier to manage, transmit, and utilize than direct currents.

#### **Points to remember**

- The magnitude of AC changes continuously.
- The direction of ac signal changes periodically
- It is produced by AC generators.
- It has a certain value of frequency
- AC signals can be easily converted into DC.
- Transmission of AC signal over higher distances is easier.
- With the same rating, AC is less dangerous than DC.

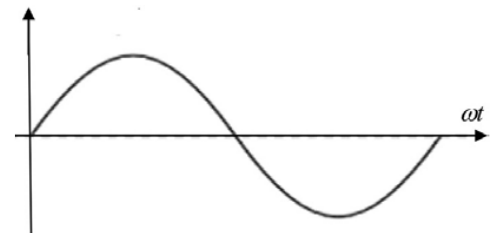

### 7.2 Difference between AC and DC

Prepare difference table between AC and DC from above note

### 7.3 Define the Following terms

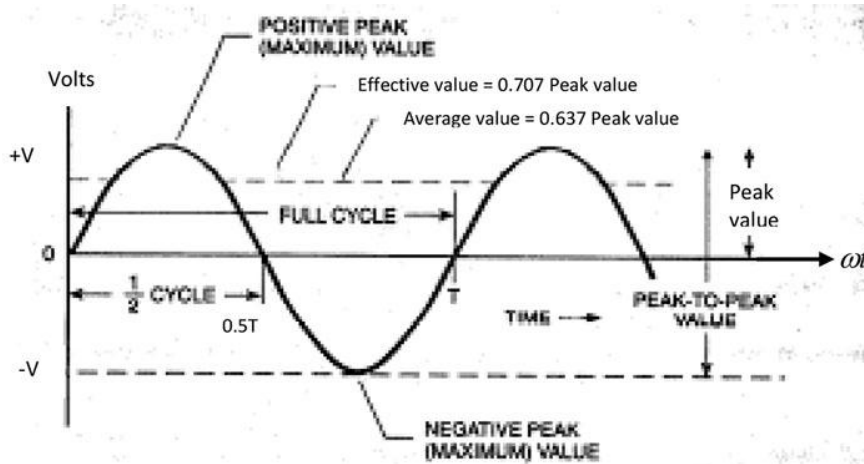

#### **a. Cycle**

When the waves move through one positive half-cycle and one negative half-cycle, then the wave is said to have completed one complete cycle.

#### **b. Time Period**

The time taken by a wave to complete one cycle is known as the time period. It is represented by 'T' and is measured in terms of seconds.

#### **c. Frequency**

The total number of complete cycles made by a wave in one second is known as frequency. It is represented by 'f' and measured in terms of Hertz (Hz).

Note:

The common power frequency in Nepal is 50 Hz i.e. the wave completed 50 complete cycles in 1 second.

The relation between time period and frequency of the wave is given by

Frequency ( $f$ ) =  $1/T$ , where  $T$  = time period

#### **d. Wavelength**

distance covered by a wave while completing one cycle is known as the wavelength of the wave. It is represented by ' $\lambda$ ' and its SI unit is meter

$$v = f \lambda$$

where  $v$  = speed of wave (m/s) ;  $f$  = frequency (Hz);  $\lambda$  = wave length

### e. Amplitude (Peak value)

The maximum positive or negative value attained by a wave from its mean position or zero value is known as amplitude. It is denoted by 'A'.

### f. Phase

It is given by the amount of time (or angle) that has elapsed since the wave last passed through the positive zero value.

In the above figure, the phase angle of the sine wave at point A is  $\pi/2$

### g. Phase difference

The difference in time or angle between the two sine waves since they last passed through their zero values is called the phase difference between two waves.

### h. In phase

When we compare the two sine waves, if they reach the zero value or maximum (either positive or negative) at the same time or phase, then the two waves are said to be in phase. Under this condition, the phase difference between the two waves is 0.

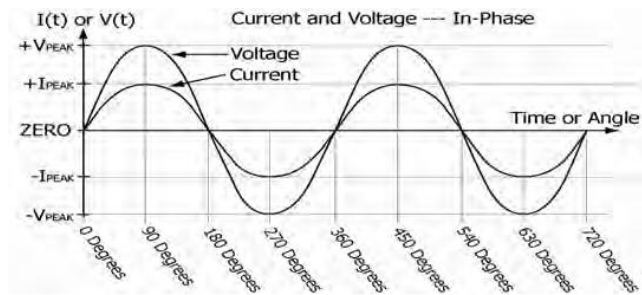

### i. Anti-phase or Out-phase

In comparing the two waves, if they reach the zero value at the same time but when one of the waves reaches the positive maximum, and the other wave reaches the negative maximum, then the waves are said to be in anti-phase or out-phase. During this condition, the phase difference between the waves is 180.

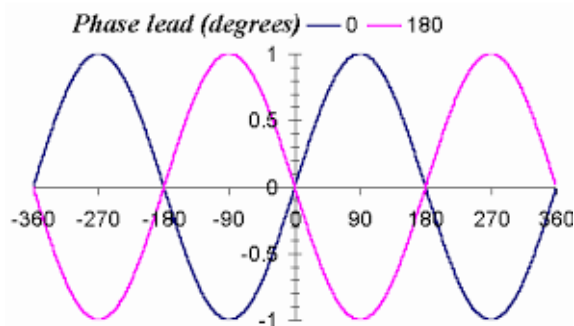

## **7.4 Difference between single phase and three phase**

### **Single Phase**

A single-phase AC power system consists of two wires known as the phase( or sometimes a line or live or Hot). The load is carried by the phase wires while the neutral wire serves as a channel for returning current.

#### **Points to remember**

- In a single-phase the flow of electricity is through a single conductor.
- In a single-phase power supply, The voltage may reach up to 230 volts
- For a smooth flow of electricity on a single-phase connection, it requires two separate wires. One represents the neutral wire and another one represents a single phase.
- Power transfer capability is compared to the three-phase system
- Single phase connection has one phase wire , if there is anything happen to the network the complete power supply gets interrupted.
- Overall efficiency is low.

### **Three phase system**

Polyphase systems include three or more energized electrical conductors that carry alternating currents with a distinct phase difference between the voltage waves in each conductor. The most prominent example is the three-phase power system, which is utilized in industrial applications and for power transmission.

#### **Points to remember**

- Three-phase consist of three separate conductors that are needed for transmitting electricity.
- In three-phase connection, it can carry a voltage of up to 415 Volts.
- In three-phase connect, the system requires one neutral wire and 3 phase wire to complete the circuit
- Maximum power gates transmitted on a Three-phase connection compared to single phase power supply
- The network is complicated on a three-phase connection because there are four different wires
- In a three-phase power supply if anything happens to a single phase the other phase still works. As such, there is no power interruption.